

Model: ST2 Series
Automatic Labeler System
2-Sided Front and Back System
-Optional
Round Bottle Wrap Unit

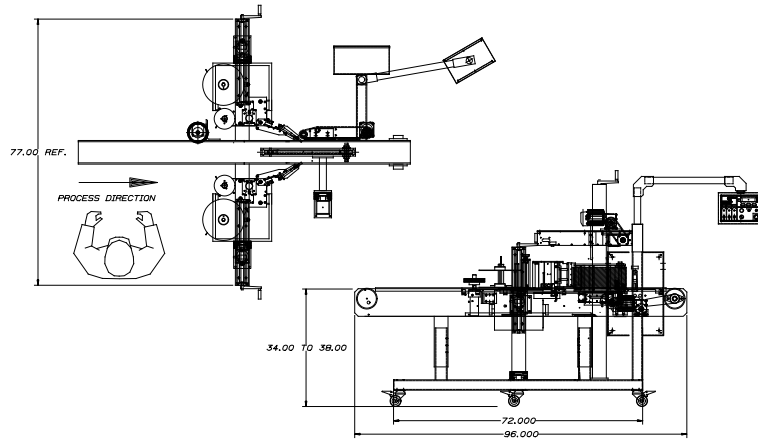

U.S. PACKAGING EQUIPMENT, LLC



Applicator System Specifications

- Speed:** 600/1100/2100/3100 linear inches per minute
- Accuracy:** +/- 1/32 of an inch with consistent product dimensions
- Control Electronics:** Microprocessor controlled
- Label Size:** Minimum: 1/2-inch by 1/2-inch
Maximum: 6-1/2" by 18.00"
- Electrical:** 110 VAC, 50/60 Hertz, 15 Amps
- Product Detection:** Photoelectric
- Label Capacity:** 6-1/2" Web Width, 12-inch/16-inch/18-inch diameter label roll capacity with a 3-inch core
- Options:** Stainless Steel Base
Stainless Steel Wash Down
Optional Wrap Station
3/4/5 Panel Station
Optional Conveyor Lengths and Widths
Dual Powered Alignment Belts
Error/Warning Light Pole
Secondary Impression Kits
Custom Product Handling
Gap Transporter Belts

U.S. PACKAGING EQUIPMENT, LLC

1464 Market Circle, Port Charlotte FL 33953
sales@uspackagingequipment.com
www.uspackagingequipment.com

Phone: 708-990-9081