

THIS DOCUMENT IS THE EXCLUSIVE PROPERTY OF U.S. PACKAGING EQUIPMENT AND MAY NOT BE USED OR REPRODUCED, NOR ITS CONTENT BY ANY PERSON OR COMPANY WITHOUT THE WRITTEN CONSENT FROM U.S. PACKAGING EQUIPMENT

REVISION DESCRIPTION	DATE	INIT
REV	D/M/YR	INT

← DIRECTION RIGHT TO LEFT

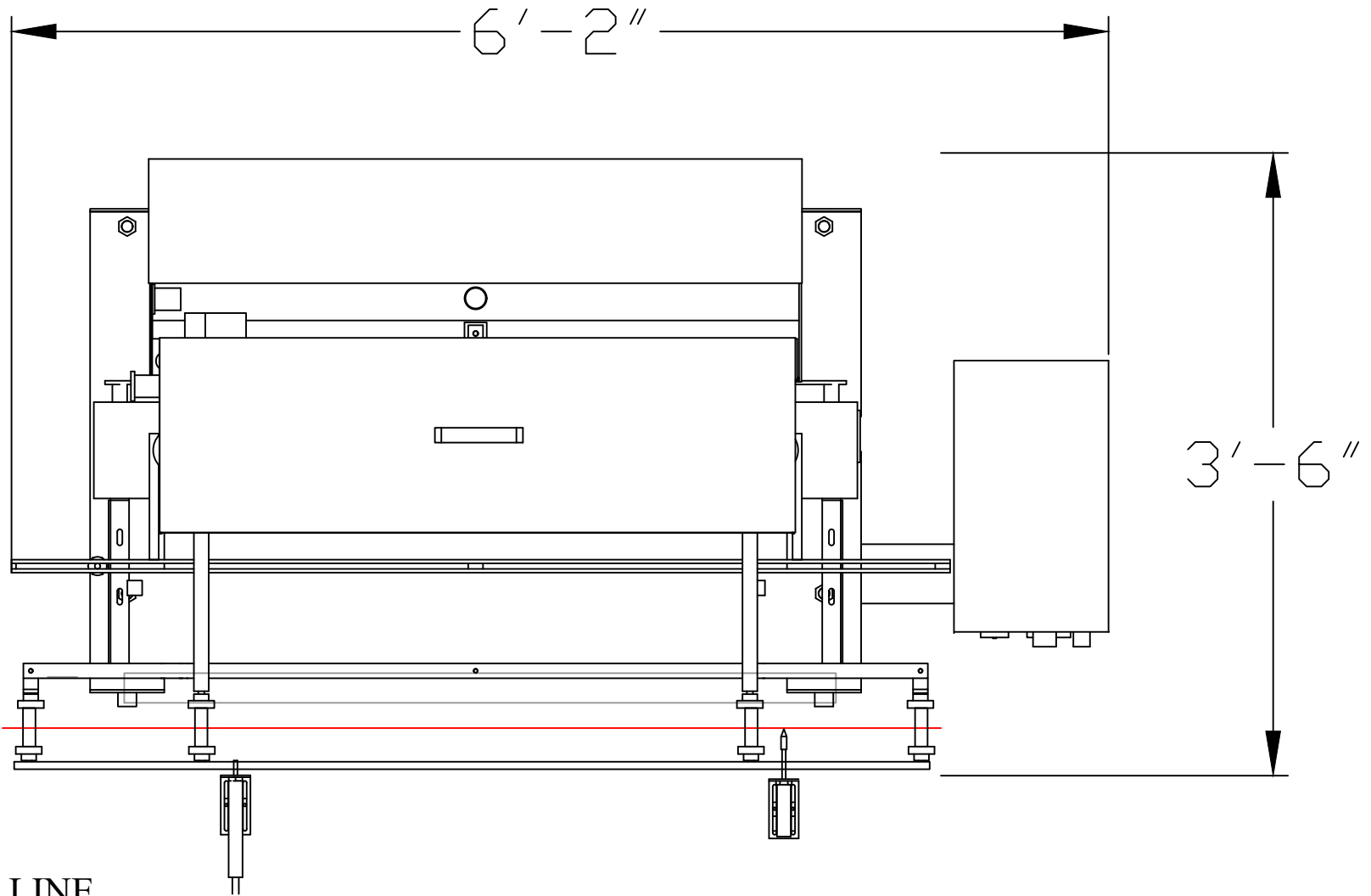

CONVEYOR LINE
HEIGHT: 36" +/-2"

APPROVAL DRAWING

DRAWN BY: JB	DATE: 8/10/2017	CHECKED BY:
DOOR DIM :	_____	
ROOM DIM :	_____	
CEILING HT:	_____	

PUMP FILLER AUTOMATIC	
SALES ENGINEER	CONTACT #:



U.S. PACKAGING EQUIPMENT
PORT CHARLOTTE, FL 708-990-9081
ALL DIMENSIONS ARE IN FEET AND
INCHES UNLESS OTHERWISE SPECIFIED

<input type="checkbox"/> APPROVED <input type="checkbox"/> APPROVED AS NOTED <input type="checkbox"/> RESUBMIT SIGNED _____ DATE _____	SHEET:
--	--------