

# EZ-Pack

## Semi-Automatic Pack Station



When you need to boost production but your operation just doesn't warrant full automation, the Combi EZ-Pack provides a semi-automatic solution for your manual packing lines. The simple, rugged design features an operator-assisted case former, product infeed conveyor, pack station and sealer. The Combi EZ-Pack allows one person to form, pack and seal corrugated cases in a single operation. A cost-saving step up from manually erecting and taping boxes, this value priced pack station boosts efficiencies while reducing the threat of repetitive stress injuries. 3M™ Accuglide™ tape heads efficiently seal top and/or bottom flaps and the modest footprint takes up little floor space. Tape roll changes are easy, and changeovers simple and repeatable.

### Features:

- Combi Four Flap folding device, operator assisted
- Lifetime warranty on structural framework
- Right hand or Left hand execution
- V-Guide side drive belts for straight tracking
- 3M™ Accuglide™ tapehead
- Quick changeover from case size to case size
- Compact Footprint
- Product Infeed Conveyor and Weigh Scale Options



# EZ-Pack

## Operation Sequence:

The operator manually opens the case and places it into the flap-folding chamber. This device automatically senses the case and the bottom four flap folding mechanisms close the flaps, keeping the case contained. The operator's hands are now free to pack the case. Once the case is packed, the operator folds the rear minor flap and gives the case a push forward. The side belt drives of the case sealer take over and the top leading minor flap and the majors are automatically closed. The case is sealed top and bottom and the case discharges from the machine.



	Min Case Size (LxWxH)	Max Case Size (LxWxH)	Speed*	Footprint
EZ-Pack	8 x 6 x 5" (203x152x127mm)	24 x 16 x 18" (610x406x457mm)	up to 15	3'6" x 6'4" (107x193 cm)
EZ-Pack XL	10 x 10 x 5" (254x254x127mm)	30 x 24 x 18" (762x610x457mm)	up to 12	4'4" x 7'1" (132x216 cm)

\* Operator/Product/Pack Pattern dependent

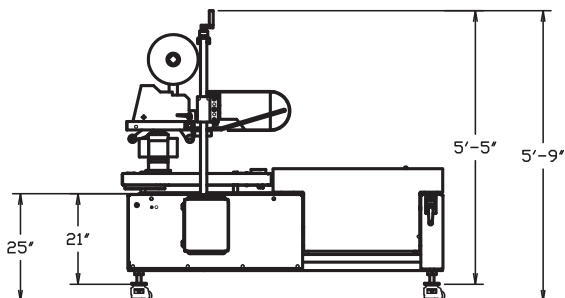
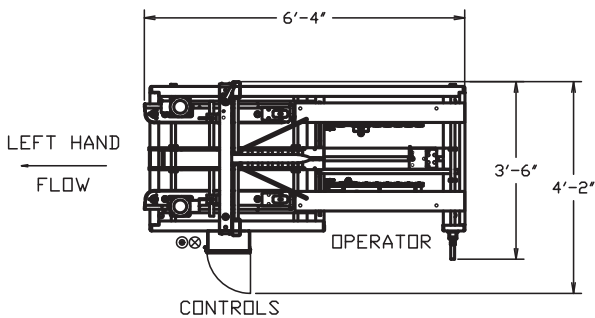

Dimensions shown of base machine only

## Distributed by:



U.S. PACKAGING EQUIPMENT LLC  
1464 Market Circle  
Port Charlotte, FL 33953  
PH: 708-990-9081

sales@uspackagingequipment.com  
www.uspackagingequipment.com

**Combi**  
Packaging Systems LLC

5365 East Center Dr. NE Canton, OH 44721  
Phone: 1-800-521-9072 Fax: 330-456-4644

www.combi.com  
© 2015 Combi Packaging Systems LLC